

# LOW AIR PRESSURE COMBUSTION EQUIPMENTS



**LOW AIR PRESSURE  
OIL/GAS/DUAL FUEL BURNERS**



**FURNACE OIL HEATING  
PUMPING FILTERING UNIT**

**TECHNICAL SPECIFICATIONS :-**

Burner Size	Oil consumption lit/hrs	Oil connection BSP	Air connection BSP	Total pressure MM WG	Blower Capacity m <sup>3</sup> /min	Blower Power (H.P.)	Oil Preheater (kW)
LAP - 00	2-6.5	3/4"	1"	500	4.5	1	1
LAP - 0	5-12	3/4"	1-1/2"	550	7	2	2
LAP - 1	8-30	3/4"	2"	600	10	3	3
LAP - 2	20-60	1-1/4"	3"	600	15.5	5	4.5
LAP - 4	32-110	1-1/4"	4"	700	30	7.5	6
LAP - 6	80-250	1-1/4"	6"	800	65	15	18

**SAVE FUEL  
SAVE MONEY**



# LOW AIR PRESSURE COMBUSTION EQUIPMENT

## SYSTEM LAYOUT

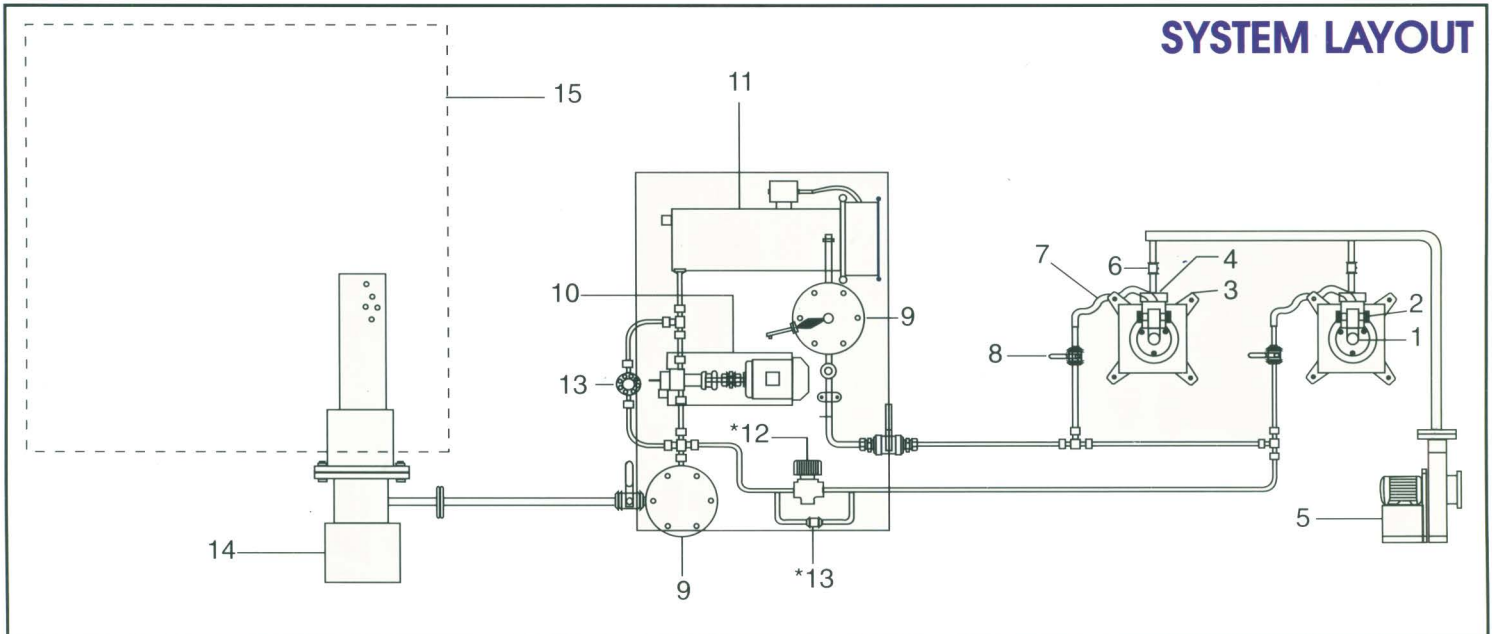

- |                         |                      |                                     |
|-------------------------|----------------------|-------------------------------------|
| 1. BURNER               | 6. BUTTERFLY VALVE   | 11. OIL PREHEATER                   |
| 2. OIL CONNECTION       | 7. FLEXIBLE OIL PIPE | *12. BACK PRESSURE REGULATING VALVE |
| 3. FRONT MOUNTING PLATE | 8. BALL VALVE        | *13. BYPASS VALVE                   |
| 4. AIR CONNECTION       | 9. OIL FILTER        | 14. OUTFLOW HEATER                  |
| 5. BLOWER               | 10. PUMPING UNIT     | 15. SERVICE TANK                    |
- \*(OPTIONAL)



**FURNACE OIL OUT FLOW HEATER**



**HIGH TEMPRATURE GAS BURNER**

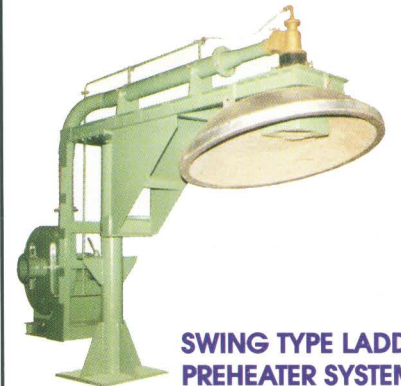

**SWING TYPE LADDER  
PREHEATER SYSTEM**

**ENSURE OPTIMUM ATOMIZATION AND EFFICIENT COMBUSTION**



**VACUNAIR  
ENGINEERING  
CO. PVT. LTD.**

Near Gujarat Bottling, Rakhial,  
Ahmedabad - 380023.INDIA.

Phone : +91-79-22910771-2-3

Fax : +91-79-22910770

Email : info@vacunair.com

website : www.vacunair.com